

Balanced Transconductor-C Ladder Filters With Improved Linearity

Antonio Carlos M. de Queiroz
 COPPE/EP - Electrical Engineering Program,
 Federal University of Rio de Janeiro
 Rio de Janeiro, RJ, Brazil

Abstract—Balanced transconductor-C filters simulating passive LC ladder structures can be built with different arrangements of the balanced transconductors, what reduces the input voltages over the transconductor inputs, reducing the nonlinearity of the filter. The need of common-mode feedback circuits can also be eliminated by structural changes in the transconductors. The paper investigates the synthesis procedure and the stability properties of these modified filters.

I. INTRODUCTION

Transconductor-C filters are an attractive choice for applications where a tunable filter is required. Even when the tunability in frequency is not a requisite, these filters can easily be used with an automatic frequency tuning system, to compensate for process and environment variations that would turn difficult the fabrication of a correctly tuned fixed filter. Structures are well known for realizations of simple filters as biquads, that can be cascaded for more complex filters, for simulations of passive doubly-terminated LC filters [1], preferred for their low sensitivity to element variations, and for other kinds of filters. While transconductor-C filters are convenient in several aspects, a major problem with them is relatively poor linearity. The linearity is controlled by the characteristics of the transconductors used, and with the available active elements, usually MOS transistors, they are unavoidably somewhat nonlinear. Moreover, if the transconductances are made to be adjustable, the nonlinearity usually depends on the transconductance control, generating filters that are more or less linear depending on the tuning.

Linearity can be improved with the use of balanced structures, what leads to a cancellation of even-order nonlinearities. These structures are also less sensitive to external interferences in the noisy ambient of a chip containing analog and digital functions, what leads to a preference for balanced filters in many applications.

Recently, an interesting technique was described for the reduction of nonlinearity in transconductor-C filters [2]. By simply rearranging the connections of the transconductors in a conventional balanced biquad, avoiding the application of large signals taken from opposite sides of the balanced struc-

ture to the inputs of the transconductors, it was possible to obtain a significant improvement in linearity.

This work investigates the possibility of the application of the same technique to LC ladder simulations, in the doubly terminated case and in the singly terminated case. It is shown that the technique is not fully applicable in the case of double termination, although significant improvement can be achieved, but is fully applicable in the case of single termination. An investigation about stability due to common-mode signals, and about how to apply common-mode feedback, or to avoid its need using the idea in [3], is also included.

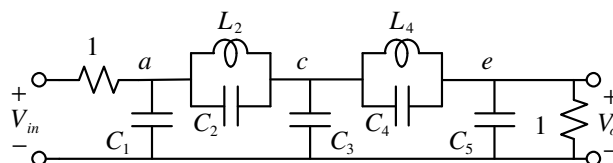

Figure 1. Normalized 5th-order LC doubly terminated filter.

II. CONVENTIONAL DOUBLY TERMINATED LADDER SIMULATION

Consider the normalized LC ladder low-pass filter shown in fig. 1. The structure is adequate for a 5th-order elliptic filter, inverse Chebyshev filter, or variations. A single-ended transconductor-C filter can be obtained by replacing the resistive terminations by transconductors and by implementing the floating inductors using gyrators and grounded capacitors. The capacitive network can be kept as in the prototype. The resulting basic normalized structure with $Gm = \pm 1$ S for all transconductances is shown in fig. 2.

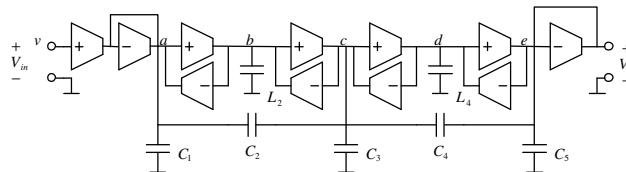

Figure 2. Transconductor-C simulation of the filter in fig. 1.

A balanced version is shown in fig. 3. It can be obtained by combining two copies of the circuit in fig. 2, using trans-

conductors having differential input and balanced output. The “upper part” is just a copy of the single-ended version, and the “lower part” a copy using the other input and output terminals of the balanced transconductors. In the normalized circuit, the transconductance is $Gm = 0.5$ S for all the transconductors, because they have their input voltages doubled in relation to the single-ended version. The final version is obtained by scaling the active circuit by adequate impedance and frequency de-normalization factors.

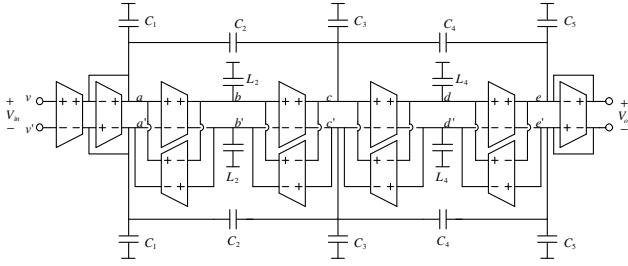

Figure 3. Balanced transductor-C filter derived from fig. 2.

A practical filter must also include some form of common-mode feedback in the transconductors. The balancing of the single-ended circuit doubles the number of capacitors, and so doubles also the complexity order of the circuit. The balanced filter is a 10th-order network, having the 5 natural frequencies of the designed filter, plus 5 extra ones generated by the balancing. If the transconductors are assumed as ideal, the 5 extra natural frequencies are at 0, corresponding to 5 undefined continuous voltage levels at the node pairs a-a', ..., e-e'. A weak common-mode feedback system is then enough to keep these voltages around zero. If the transconductors have some residual common-mode transconductance gain, the filter becomes unstable. The “common-mode natural frequencies” can be found by short-circuiting the input nodes of the transconductors and analyzing the resulting network. Assuming all the transconductors identical, with the same polarity of common-mode transconductance, the 5 extra natural frequencies are in the real axis. The gyrators form positive feedback loops that along with the capacitors generate natural frequencies in the negative and positive real axis. The terminations have positive or negative feedback if the common-mode transconductance is positive or negative, and have essentially the effect of shifting the extra natural frequencies to more positive or more negative values.

Example 1:

Consider a normalized 5th-order elliptic filter with 1 dB passband ripple, 40 dB stopband attenuation, and passband border at 1 rad/s. The structure in fig. 1 has the element values:

$$\begin{aligned} C_1: 1.41517 \text{ F} & & C_4: 0.364398 \text{ F} \\ C_2: 1.08537 \text{ F} & & L_4: 0.881628 \text{ H} \\ L_2: 0.586082 \text{ H} & & C_5: 1.84422 \text{ F} \\ C_3: 2.13067 \text{ F} & & \end{aligned}$$

If the transconductors in fig. 3 have differential transconductance $Gm = 0.5$ S and common-mode transconductance $Gc = \pm 0.1$ S (unrealistically high but chosen to clearly show the

effect), defining Gc as the ratio between the output currents at both outputs and the average value of the two input voltages, an analysis of the circuit shows that the common-mode natural frequencies are:

$Gc = +0.1$ S:	$Gc = -0.1$ S:
-0.137838	0.137838
-0.0567147	0.0567147
0.0173695	-0.0173695
0.099645	-0.099645
0.169877	-0.169877

In both cases the filter is unstable. The polarity of Gc changes the signs of the common-mode natural frequencies on the real axis. The other 5 natural frequencies are the ones of the designed filter, and are not affected. In the frequency response of the filter, the common-mode natural frequencies appear cancelled by zeros, and are not observable. Note that a practical circuit may also have significant output conductance in the transconductors, what contributes to stability but distorts the frequency response. This effect was not considered.

Common-mode feedback can be added through circuit blocks that drain from the node pairs a-a', ..., e-e' currents proportional to the average voltages at them. Five of these blocks are necessary in the example. If the common-mode transconductances are negative, less transconductance is required in the blocks, because the terminations already provide some common-mode negative feedback. The compensation circuits are equivalent to balanced transconductors with zero differential transconductance and negative common-mode transconductance Gx , with input and output terminals interconnected in parallel. It's seen that if Gc is positive, a minimum of $|Gx| = |Gc|$ is required (this leaves a natural frequency at 0). If Gc is negative, a bit less is enough. In the example, using $Gm = 0.5$ S, $Gc = \pm 0.1$ S and $Gx = -0.1$ S, the common-mode natural frequencies are obtained as:

$Gc = +0.1$ S:	$Gc = -0.1$ S:
-0.401690	-0.415179
-0.266966	-0.280950
-0.0193030	-0.100301
-0.0380737	-0.0932042
0.0	-0.0210784

III. STABLE FILTERS WITHOUT COMMON-MODE FEEDBACK

A stable filter can be obtained if the transconductors making the “return” path of the gyrators (output at the left side in the drawings) are modified so their common-mode transconductances are inverted, as shown in [3]. The common-mode natural frequencies are then scaled versions of the original filter natural frequencies, because the “common-mode circuit” has the same structure of fig. 2. If the normal Gc is positive, all the common-mode natural frequencies are in the right half-plane, and the filter is unstable. If Gc is negative, however, all are in the left half-plane and the filter is stable. There is no need of additional common-mode feedback to stabilize the filter. Considering again the same 5th-order balanced filter, with $Gm = 0.5$ S and $Gc = \pm 0.1$ S, the 10 natural frequencies are obtained as:

$G_c = +0.1 \text{ S:}$	$G_c = -0.1 \text{ S:}$
$-0.0499207 \pm 0.998198j$	$-0.0499207 \pm 0.998198j$
$-0.219107 \pm 0.741034j$	$-0.219107 \pm 0.741034j$
-0.385344	-0.385344
$0.00499207 \pm 0.0998198j$	$-0.00499207 \pm 0.0998198j$
$0.0219107 \pm 0.0741034j$	$-0.0219107 \pm 0.0741034j$
0.0385344	-0.0385344

It's seen that the common-mode natural frequencies in the example are precisely $\pm 1/10$ of the filter natural frequencies. An interesting property of this filter is that it filters common-mode signals at the input with a scaled copy of the differential filter, in this case with 0.1 dB cutoff at 0.1 rad/s.

IV. BALANCED FILTERS WITH REDUCED INPUT VOLTAGES

The signal levels in the single-ended and in the balanced filters follow the levels in the passive prototype. In the beginning of the passband, the voltages at the nodes a, a', c, c', e and e' , that correspond to the three nodes of the passive prototype, have signal levels around one half of the input signal. The voltages at nodes $b, b', d,$ and d' correspond to the inductor currents in the prototype. As in the normalized prototype this current is around $V_{in}/2 \text{ A}$ due to the two unitary terminations, the voltage levels there are also close to one half of the input voltage. These relations are kept in a denormalized circuit.

The idea used in [2] is to reorganize the inputs of the balanced transconductors so they have both inputs connected to the same side of the balanced circuit. In the circuit in fig. 3, the reorganization can be done by rearranging the currents fed to the nodes as follows:

$$\begin{aligned}
 i_a &= Gm(v-v'+a'-a+b-b') = Gm(v-b+b'-v'+a'-a) \\
 i_{a'} &= Gm(v'-v+a-a'+b-b') = Gm(b-v+v'-b'+a-a') \\
 i_b &= Gm(a-a'+c'-c) = Gm(a-c+c'-a') \\
 i_{b'} &= Gm(a'-a+c-c') = Gm(c-a+a'-c') \\
 i_c &= Gm(b-b'+d'-d) = Gm(b-d+d'-b') \\
 i_{c'} &= Gm(b'-b+d-d') = Gm(d-b+b'-d') \\
 i_d &= Gm(c-c'+e'-e) = Gm(c-e+e'-c') \\
 i_{d'} &= Gm(c'-c+e-e') = Gm(e-c+c'-e') \\
 i_e &= Gm(d-d'+e'-e) = Gm(d-e+e'-d') \\
 i_{e'} &= Gm(d'-d+e-e') = Gm(e-d+d'-e')
 \end{aligned} \tag{1}$$

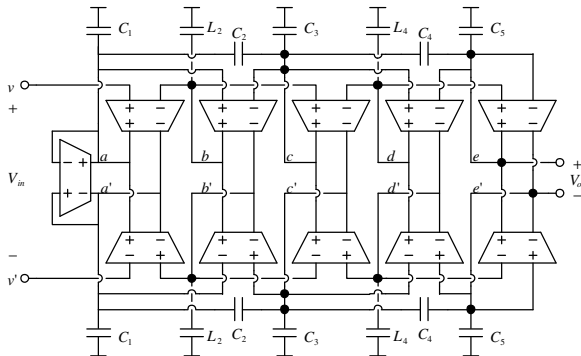

Figure 4. Balanced filter of fig. 3 with rearranged transconductor inputs.

The corresponding filter structure is shown in fig. 4. It's possible to rearrange all the inputs, except for the inputs of the transconductor that realizes the input termination. Fig 5 shows the signal levels at the inputs of the original filter (fig. 3), and fig. 6 the corresponding levels at the modified filter. The levels are represented by the voltage gains from the input to them. It can be observed that significant level reductions are obtained at all frequencies below the passband edge. The largest level, which was at the input transconductor, is converted into two signals with about one fourth of the amplitude.

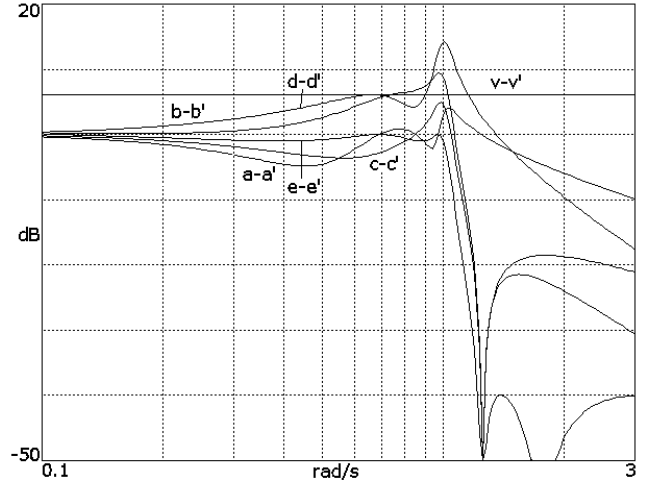

Figure 5. Input signal levels at the transconductors in the normal doubly-terminated balanced filter.

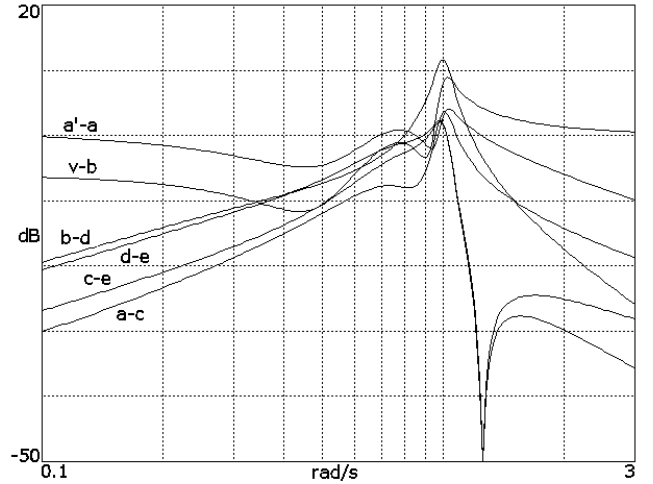

Figure 6. Input signal levels on the modified doubly-terminated filter.

V. STABILITY OF THE MODIFIED BALANCED FILTER

The different connections of the transconductors don't affect the positions of the common-mode natural frequencies, if all the transconductors are identical. Stabilization can be obtained by the addition of common-mode feedback, but the compensation circuits must be added between opposite balanced nodes, as in the normal realization. The added circuits must then be designed so they don't generate differential-mode nonlinearities in the presence of large differential signals. It's not possible to obtain a stable filter by changing the

polarity of the common mode transconductance of some of the transconductors, and this would also distort the frequency response of the balanced filter.

VI. USE OF SINGLY-TERMINATED PROTOTYPE

The input termination transconductor in fig. 4 can be eliminated if a singly-terminated ladder prototype is used. The passive prototype is shown in fig. 7. Singly-terminated filters are usually not a good choice due to high sensitivity to component variations, but in this case the main concern is about linearity of the active version. The corresponding transconductor-C structures are identical to the previous ones, figs. 3 and 4, with the removal of the transconductors with inputs connected to the outputs at the left sides of the structures.

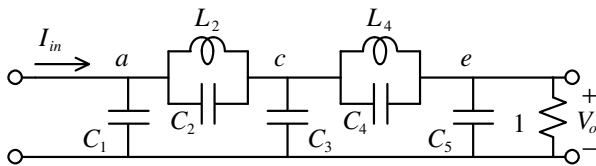

Figure 7. Singly-terminated ladder prototype. $I_{in} = GmV_{in}$.

Example 2

The same 5th-order elliptic filter, in the singly-terminated version has these element values:

C_1 : 1.20844 F	C_4 : 0.286509 F
C_2 : 0.734198 F	L_4 : 1.12130 H
L_2 : 0.866414 H	C_5 : 0.835009 F
C_3 : 1.38544 F	

Fig. 8 shows the distribution of signal levels at the inputs of the transconductors in the active prototype with the normal structure, and fig. 9 the same signals on the alternative realization. The large level at the input termination at the other filter disappears, and the levels at the differential inputs connected to the input signals are also reduced, because the division by two of the input voltage caused by the two terminations doesn't exist.

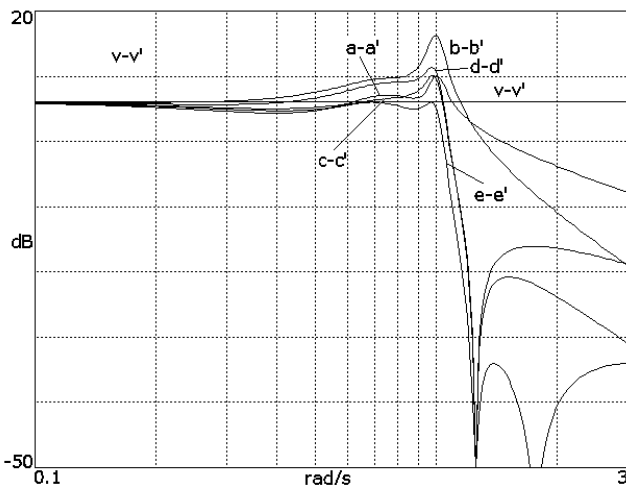

Figure 8. Signal levels at the transconductor inputs in the normal singly-terminated transconductor-C filter.

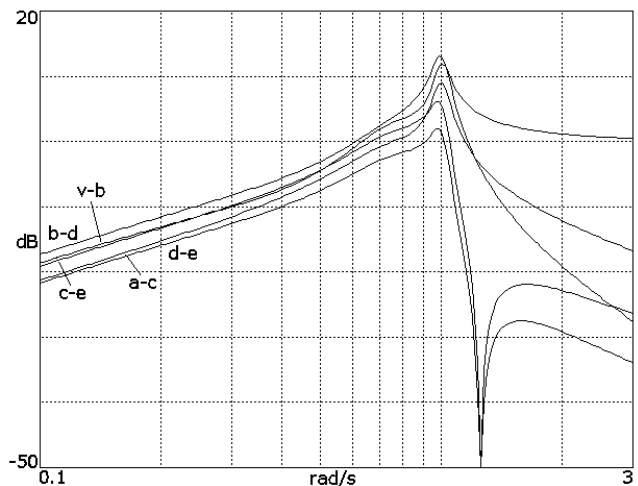

Figure 9. Signal levels at the transconductor inputs on the modified singly-terminated transconductor-C filter.

In this paper, as in [2], it's considered that transconductors with true differential input are used. It is also possible to build these filters using only single-ended inverting transconductors, but then the common-mode stability conditions are much more severe, because just due to the regular transconductances the filter is unstable, and strong common-mode feedback is required [1]. There is no advantage in applying the described ideas to those filters.

VII. CONCLUSIONS

The possibility of designing transconductor-C ladder filters with reduced nonlinearity by rearranging the inputs of the transconductors was demonstrated. The technique can be applied exactly to singly-terminated passive prototypes, and also to doubly terminated prototypes, although one of the transconductors continues to receive differential signals at its input. What can actually be obtained in linearity improvement depends on the exact construction details of the transconductors, and was not shown in this limited paper, but with any given transconductor some linearity improvement must appear just due to the smaller input signals. It was also shown that a balanced filter can be stable without explicit common-mode feedback circuits, but that the idea can't be directly applied to the modified structures with reduced nonlinearity, that still require common-mode feedback circuits.

REFERENCES

- [1] J. Schechtman, A. C. M. de Queiroz, and L. P. Caloba, "A high performance balanced MOS transconductor," 36th MWSCAS, Detroit, USA, August 1993, pp. 1378-1381.
- [2] A. Tajalli and Y. Leblebici, "Linearity improvement in biquadratic transconductor-C filter," Electronics Letters, Vol. 43, No. 24, November 2007.
- [3] T. Sato, S. Takagi, S. Ao, and N. Fujii, "Realization of Fully Balanced Filter Using Low Power Active Inductor," ICECS 2008, St. Julians, Malta, September 2008, pp. 133-136.